



# Sailing Instructions

## 2023 RS Tera North American Championship

### Jordanelle State Park, Heber City, Utah

### September 8-10, 2023

### Organizing Authority

### Park City Sailing Association

**Note: NOR revision of 7-6-23 correcting dates in Additional Information**

**1. RULES**

- 1.1. The regatta will be governed by the rules as defined in The Racing Rules of Sailing 2021-2024 and the RS Tera Class Rules except as any of these are changed by these Sailing Instructions or any appendices or amendments to the Sailing Instructions.
- 1.2. Rule 40.1 (PFDs required) will be in effect. Note that Flag Y may not be displayed. This changes Rule 40.2
- 1.3. The US Sailing prescription Appendix U applies and is modified as follows: In U5, the word “adequate” is deleted.
- 1.4. Appendix V, “Alternative Penalties” V1 “Penalty at time of Incident” and V2 “Post Race Penalties” apply
- 1.5. In the event of a conflict between the Notice of Race and the Sailing Instructions (SIs) or Amendments to SIs, the SIs and amendments will prevail.

**2. NOTICES TO COMPETITORS**

- 2.1 Notices to Competitors will be posted on the Official Notice Board located on the north window at the Lakeview Center (LVC): the Regatta Office, adjacent to the Personal Watercraft Ramp at Jordanelle State Park. Notices will also be posted online at: [Official Notice Board — Park City Sailing \(sailpc.org\)](http://Official Notice Board — Park City Sailing (sailpc.org)) or <https://sailpc.org/official-notice-board>
- 2.2 Competitors’ Meeting will be held at 1000 on Saturday, September 9 on the lower patio, lake side of the LVC

**3. CHANGES TO SAILING INSTRUCTIONS**

- 3.1. Changes to the sailing instructions will be posted before 0900 on the day they will take effect except that any change to the schedule of races will be posted by 2000 on the day before it will take effect

**4. SIGNALS MADE ASHORE**

- 4.1 Signals made ashore will be displayed in the area next to the Personal Watercraft Ramp
- 4.2 When flag AP is displayed ashore, “1 minute” is replaced with “not less than 30 minutes” in Race Signals: AP

**5 SCHEDULE OF EVENTS and RACES**

<i>Day and Date</i>	<i>Time</i>	<i>Event</i>
Friday, September 8	1400-1700.	Practice Races
Saturday, September 9	830-1000	Check In
Saturday, September 9	1000	Competitors Meeting
Saturday, September 9	1130	First Warning
Sunday, September 10***	1030	First Warning for races
Sunday, September 10	1700	Awards

\*\*\*No warning signal will be made after 1530 on the final day of the regatta.

## **6 CLASS FLAGS**

6.1 The Race Committee shall communicate the next class to start by hail and/or notice board on the signal boat starting no later than the attention signal for that class. Competitors should remain in the vicinity of the signal boat while awaiting such hails and or postings, however they must keep clear of any boats Racing. Class flags and/or symbols to be used on noticeboards will be described at the Competitors' Meeting.

## **7 FLIGHT SELECTION QUALIFICATIONS AND CHAMPIONSHIP SERIES FOR SPORT FLEET**

7.1 *NOTE: This amends the Notice of Race.* The description of flights and series described detailed in the NOR section 4, may be significantly amended and simplified subject to the number of registrations for each the SPORT and PRO Fleets. A minimum of 3 Fleet entrants will be required to create a separate Fleet start, scoring and awards. A minimum of 20 Fleet entrants will be required to establish separate Flights. Final plans will be provided in the form of an amendment to the SIs.

## **8 RACING AREA**

8.1 The Racing Area(s) for all fleets will be South and/or Southeast of the Personal Watercraft Ramp at Jordanelle State Park

8.2 The signal boat in use will be described at the Competitors' Meeting.

## **9 COURSES**

9.1 The Courses are described in Addendum A of these Sailing Instructions

9.2 The Race Committee shall communicate the course by hail and/or noticeboard on the signal boat starting no later than the attention signal for the next class to start.

## **10 MARKS**

10.1 Marks to be used are described below:

- a. Orange balls
- b. Orange inflatable cylinder
- c. Orange inflatable tetrahedron
- d. White balls (may be set for the end of start or finish lines)
- e. Additional moveable marks may be used. If so, they will be described during the Competitors' Meeting

## **11 THE START**

11.1 The Order of Starts will be detailed in an amendment to the Sailing Instructions

11.2 Before the first warning each day, each competitor is required to check in with the Signal Boat and announce competitor's name and sail number.

11.3 Races will be started using the Audible-Signal Racing System in RRS Appendix U and described in Addendum B. This changes RRS 26

11.4 The start line at the signal vessel is between an orange flag on a staff (or port spreader) on the signal vessel at the starboard end and the course side of an inflatable buoy at the port end.

11.5 Boats whose warning signal has not been made shall avoid the starting area during the starting sequence for other races.

11.6 A boat that does not start within 3 minutes after her starting signal may be scored Did Not Start (DNS) without a hearing. This changes RRS A5.1 and A5.2

11.7 The start and finish lines at the signal vessel are **closed** to all boats, except for:

- a. Boats from their class warning signal until they have started
  - b. Boats approaching the line to finish until they have finished and cleared the line
  - c. Boats sailing a course where a mark that bounds either the start or finish line is the next mark they must round.
- Boats that cross the start or finish lines at any other time may be scored "Did Not Sail the Course" (NSC) without a hearing. This changes RRS 5.1 and 5.2

## **12 RECALLS**

12.1 As a courtesy, the race committee will attempt to hail On Course Side (OCS) boats. Failure to execute this hail or failure to receive it shall not relieve a boat or her sole obligation to start properly, nor shall it constitute an improper action or omission of the race committee under RRS 62.1(a)

## **13 CHANGE OF THE NEXT LEG OF THE COURSE/ CHANGE OF START or FINISH LINES**

13.1 The race committee may change a leg of the course by up to fifteen (15) degrees and/or .1nm in length without a signal.

13.2 After the start signal, without making any signals, the race committee may move either or both of the start and finish line marks during a race, the start and finish line marks shall be in position before the first boat passes the last mark of the course and not changed again until after the last boat has finished or the time limit has expired.

## **14 THE FINISH**

14.1 The finish line will be between a staff displaying a blue flag on the RC Signal Boat and a mark on the starboard side of the RC boat

## **15 TIME LIMITS**

15.1 The time limit for each race will be 40 minutes

15.2 Boats finishing greater than 10 minutes after the first boat in her class sails the course and finishes will be scored DNF without a hearing. This changes Rules 35, A4 and A5

## 16 SCORING

- 16.1 The number of races scheduled is 8. The minimum number of races required to constitute a regatta is 1.
- 16.2 When 4 or fewer races have been completed, a boat's series score will be the total of her races scored. When 5 or more races have been completed, a boat's series score will be the total of her race scores excluding her worst score. This changes Rule A2.1

## 17 PROTESTS AND REQUESTS FOR REDRESS

- 17.1 Competitors intending to protest shall inform the race committee of the protestee after the finish of the race.
- 17.2 For each class, the Protest Time Limit is 30 minutes after the last boat in the class finishes the last race of the day OR the Race Committee returns to the dock, whichever is later.
- 17.3 A request for a hearing may be handed to the Race Committee in hardcopy or sent by email to [RaceCommittee@Sailpc.org](mailto:RaceCommittee@Sailpc.org). If sent by email, the time stamp of delivery to the email box will be used to determine if the request was delivered within the time limit.
- 17.4 Notices will be posted on the Official Notice Board within 30 minutes of the protest time limit to inform competitors of hearings in which they are parties
- 17.5 Notices of protests by the Race Committee or Protest Committee will be posted to inform boats under rule 61.1(b)
- 17.6 If the Race Committee posts a list of boats scored OCS, ZFP, UFD, or BFD on the official notice board before the protest time limit, a request for redress based on such a posted score shall be made no later than sixty (60) minutes after the protest time limit. This changes the first sentence of RRS 62.2
- 17.7 On the last scheduled day of racing, a request for redress on a protest committee decision, or a request to reopen a hearing shall be delivered no later than sixty (60) minutes after the decision was announced, either written or orally. This changes RRS 62.2 and RRS 66.

## 18 SAFETY REGULATIONS

- 18.1 A boat that retires from a race shall notify the race committee at the first reasonable opportunity

## 19 TRASH DISPOSAL

- 19.1 Competitors and support persons are reminded that overboard disposal of trash is not permitted. Trash may be placed aboard support and officials' boats. Competitors are required to use refillable water bottles. A water spigot is available for refills both on shore and on the water. Violation of these rules will be considered grounds for protest and disqualification.

## 20 ADVERTISING

- 20.1 Advertising permitted in accordance with class rules and World Sailing Regulation 20.
- 20.2 Boats may be required to display advertising supplied by the Organizing Authority
- 20.3 By participating in this event, all competitors (by parents or legal guardians of minors) acknowledge that they grant the Organizing Authority, its sponsors and the National and International Class Associations the unconditional right and authority, in perpetuity, to publish and broadcast anywhere in the world, for any purpose and in any media, the names, images, and biographical information relating to the competitors and photographs, video footage, and audio recordings taken of the boat and skipper prior to, during, and after the races without compensation.

## 21 RISK STATEMENT AND DISCLAIMER OF LIABILITY

- 21.1 RRS 3 states: "The responsibility for a boat's decision to participate in a race or to continue to race is hers alone." By registering for and participating in this event, each competitor and competitor's guardian agree and acknowledge that sailing is a potentially dangerous activity with inherent risks. These risks include strong winds and rough seas, sudden changes in weather, failure of equipment, boat handling errors, poor seamanship by other boats, loss of balance on an unstable platform and fatigue resulting in increased risk of injury. **Inherent in the sport of sailing is the risk of permanent, catastrophic injury or death by drowning, trauma, hypothermia or other causes.**
- 21.2 Competitors participate in the regatta entirely at their own risk. The Organizing Authority will not accept any liability for the material damage or personal injury, or death sustained in conjunction with or prior to, during, or after the regatta.

## ADDITIONAL INFORMATION (Subject to Change)

**PARK ACCESS:** Standard park access fees are in effect during the regatta and are the responsibility of competitors to pay when entering the park.

**PETS:** The Jordanelle State Park does welcome pets but they must be on leashes at all times.

# ADDENDUM A: Courses

**Note: On all courses the Start and Finish lines are "CLOSED" and all marks are to be rounded to Port. Start/Finish area may be rounded to either side when passing.**

Course "W": Start,1,3,Finish

Course "T": Start,1,2,3,Finish

Course "W2": Start, 1,3,1,3,Finish

Course "T2": Start, 1,2,3,1,2,3,Finish

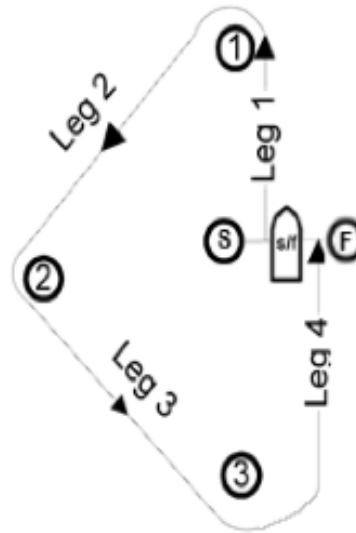
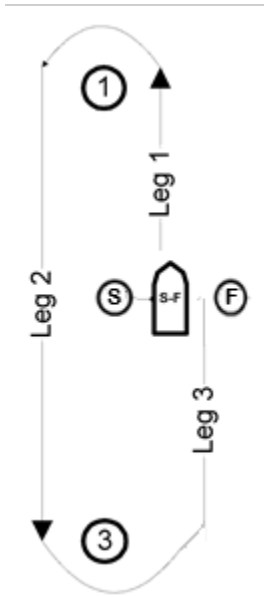

Course "G": Start,1,2,3,1,3,Finish

Course "GT": Start,1,2,3,4,3,4,Finish

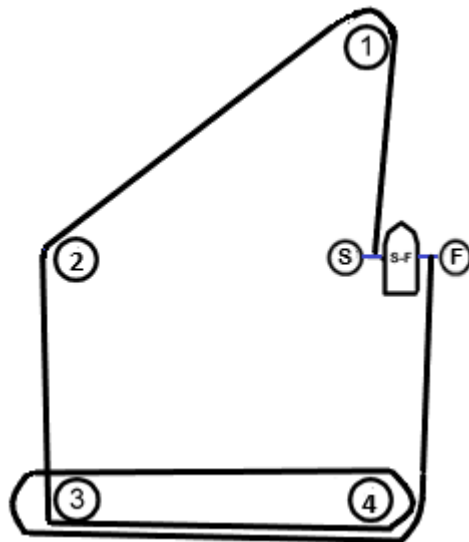
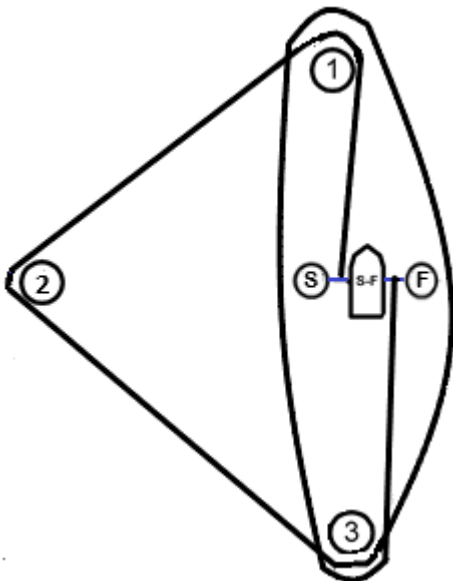



## ADDENDUM B: Audible-Signal Racing System

<u>Signal Sound</u>	<u>Time Before Start</u>
Attention	5 short 4 minutes
Warning	3 long 3 minutes
Preparatory	2 long 2 minutes
	1 long, 3 short 1 minute, 30 seconds
	1 long 1 minute
	3 short 30 seconds
	2 short 20 seconds
	1 short 10 seconds
	1 short 5 seconds
	1 short 4 seconds
	1 short 3 seconds
	1 short 2 seconds
	1 short 1 second
Starting	1 long 0 (Start)